

### COLLECTION / SCOPE OF APPLICATION

- ECD100 - without Pot Filler, with Black Spray Valve (BWSG-BRS)
- ECD110 - with 10" Pot Filler and Black Spray Valve (BWSG-BRS)
- ECD100G - without Pot Filler, with Grey Spray Valve (BWSG-BRE)
- ECD110G - with 10" Pot Filler and Grey Spray Valve (BWSG-BRE)



### DIMENSIONS

\* All product dimensions are nominal.

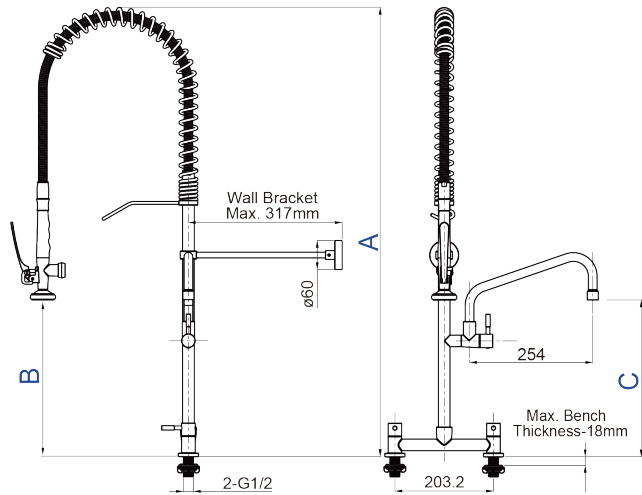

Displayed Product Ref. **ECD110**

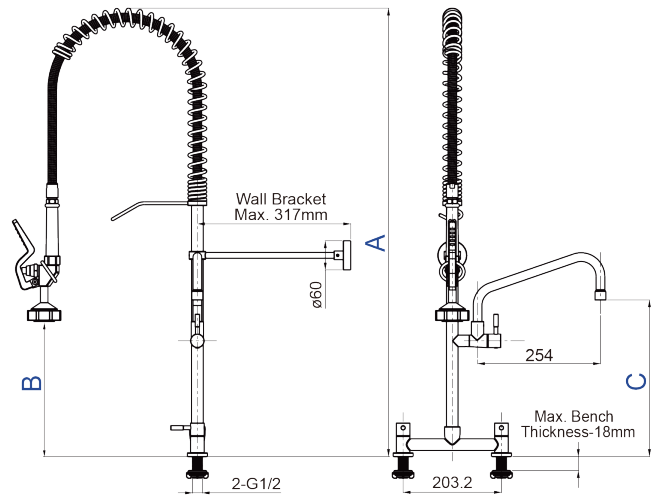

Displayed Product Ref. **ECD110G**

CODE	A (mm)	B (mm)	C (mm)
ECD100	926	360	/
ECD110	926	360	323.2
ECD100G	926	260	/
ECD110G	926	260	323.2

## GENERAL CHARACTERISTICS

- Maximum working temperature: 80°C
- Maximum static pressure: 1000kPa (10 bar)  
*RECOMMENDED WORKING PRESSURE is 500kPa (5 bar)*
- Flow rate:  
at pot filler outlet: non-pressurized aerator (for more water saving options, please contact BW customer support team.)  
at spray valve: BWSG-BRS (7.3 LPM at 500kPa) / BWSG-BRE (8.1 LPM at 500kPa)
- Bench requirements:  
Bench thickness - 18mm Maximum  
Twin holes -  $\Phi 21\sim 23\text{mm}$

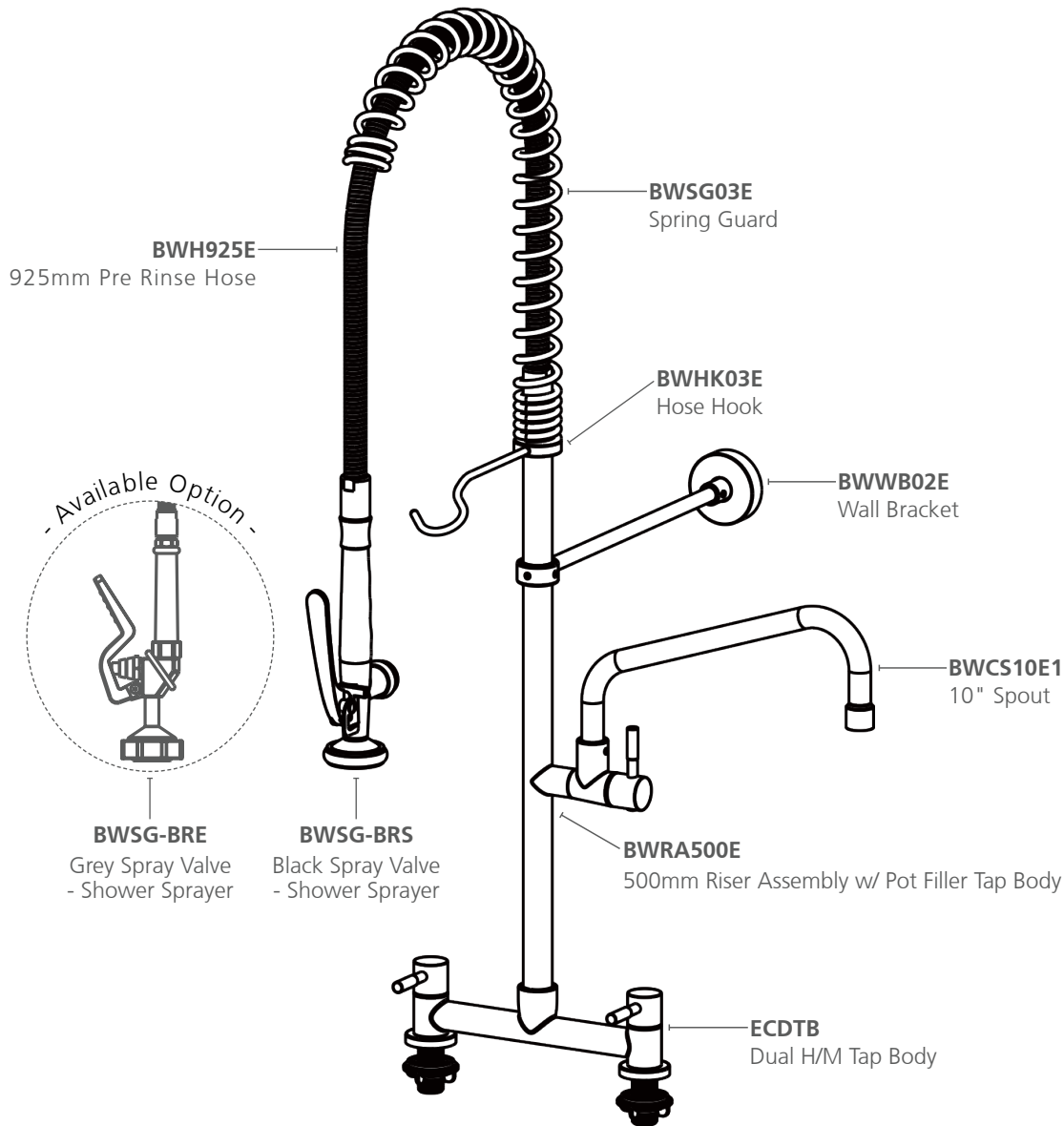

## IMPORTANT NOTES

- Bestware products must be installed by professional plumbers in accordance with current regulations and ordinances in your country.
- Before installation, turn off water supplies to existing faucet and remove faucet if replacing. Clean faucet basin and clear away debris. Flush all supply lines before connecting to faucet. Failure to do so can result in debris clogging the inlets and/or cartridges.
- The information in this manual is subject to change without notice.